

2



1

PARTS LIST

ITEM	QTY	PART NUMBER	DESCRIPTION
1	1	GR2LL5075HCB8	Shoe Moulding, Aluminum, Level lock Plus, For .5 to .75 Glass, 2.75 Wide, 3.75 High, 20 Foot Lengths, Hole Counterbored, 8 in on Center, Mill Finish
2	2	LL3421	Level Lock Plus, Mechanism 10 Pack, for 3/4" Nominal Glass, .705-.906"
3	2	GR9LL1250	Shoe Isolator, Level Lock +, HDPE, 0.125 x 0.50 x 2.00, 10 pack

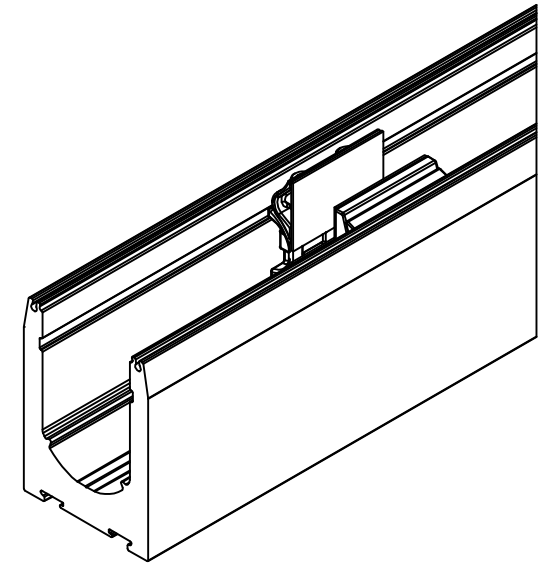
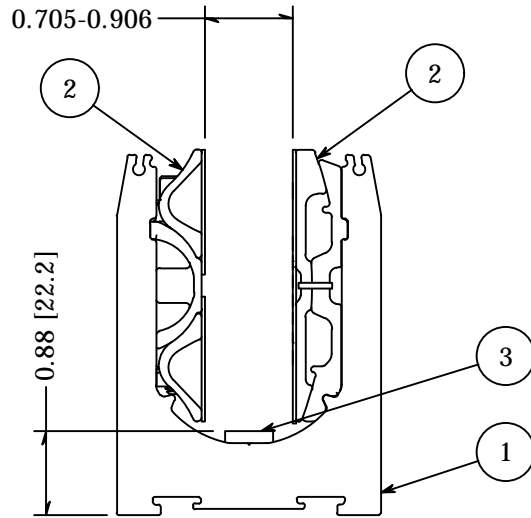

240.00 [6096.0]

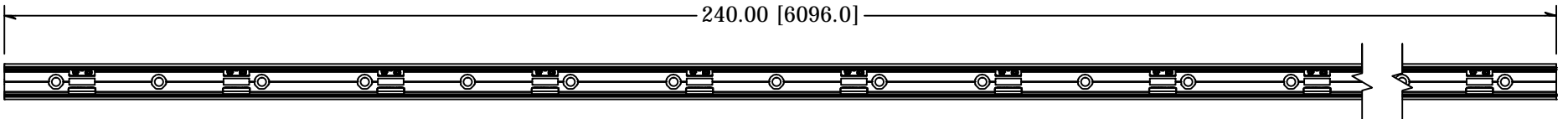

4.00 [101.6] TYP.

8.00 [203.2] TYP.

(30) Ø0.63 THRU
□ Ø1.13

TOLERANCE X.XX +/- 0.01 X.XXX +/- 0.005 Angle +/- 0.5 Unless Otherwise Specified	CUT LENGTH:	FINISH:	DESCRIPTION:	
		MILL	Level Lock Plus, Sales kit, for 3/4", 19mm-21mm glass, 20ft shoe HCB 8" O.C., W/ Mechanisms	
	DEVELOPED LENGTH:	WEIGHT:	MATERIAL:	MATERIAL DESC:
	20FT	N/A	DATE: 4/8/2021	REV: 1
TOOL NUMBER:		DRAWN BY: A. Seeboth		
		PART NUMBER: LL3421.8KIT20	 10600 W Brown Deer Rd Milwaukee, WI 53224 COLLABORATIVE METALWORKS http://www.wagnercompanies.com/	

2



1