

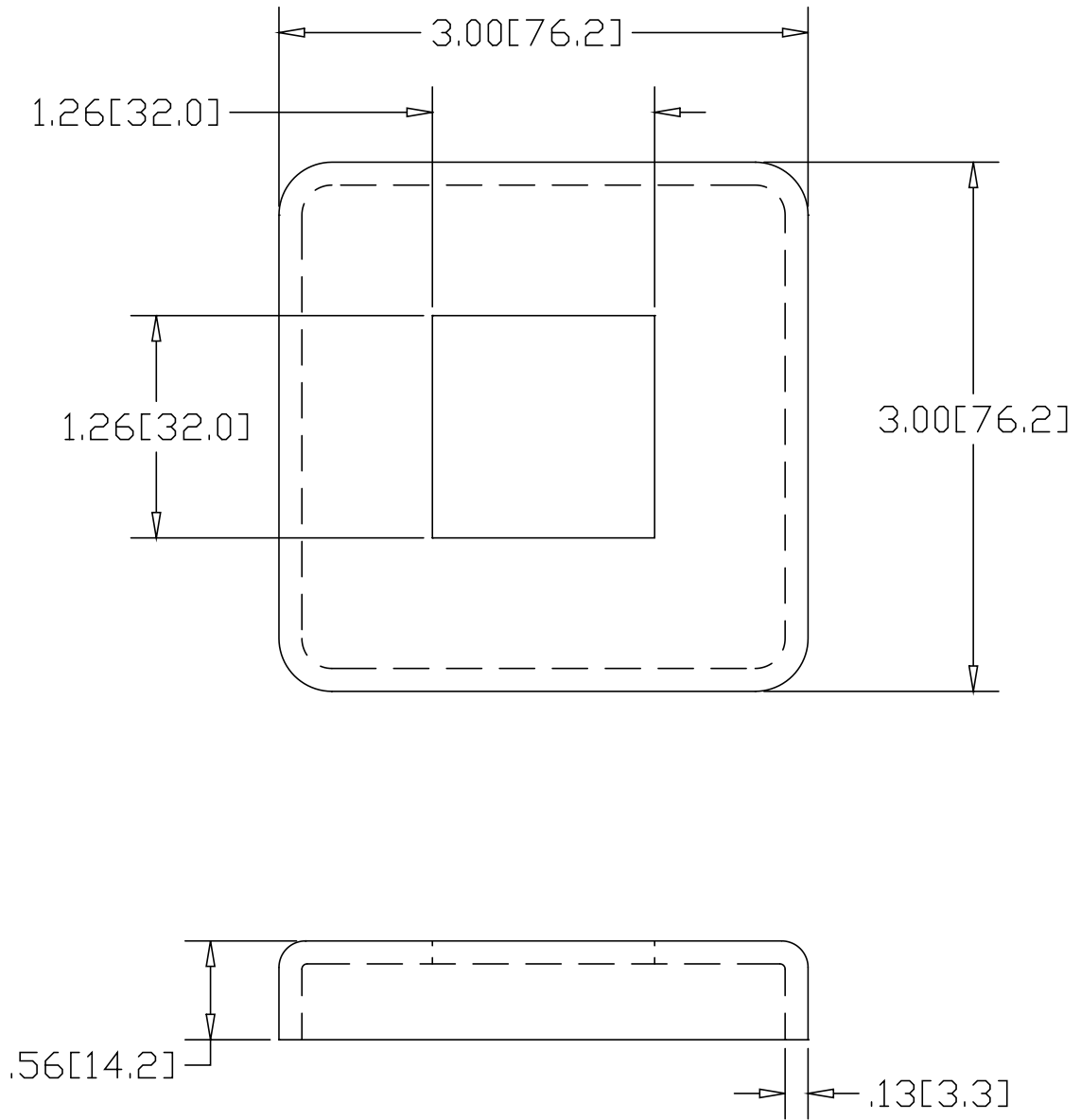

REV  
SH  
DWG NO 8715

REVISIONS			
REV	DESCRIPTION	DATE	APPROVED



INCHES [MILLIMETERS]

ALTERNATE MATERIAL	PART NUMBER
.125 (3003) ALUMINUM ASTM B209	8785
10 GA. (304) STAINLESS STEEL ASTM A240	8855

PART NAME		1-1/4" SQUARE TUBE HFB FLANGE	
MATERIAL		10 GA. HRP&O STEEL ASTM A569	
DATE	6/20/95	 <b>R &amp; B WAGNER, INC.</b>	
DRAWN BY	RJF		
FINISH	MILL	SIZE	A
		WEIGHT	.42 LBS
		PART NUMBER	8715
		REV	