

REV
SH
8053
DWG NO

REVISIONS			
REV	DESCRIPTION	DATE	APPROVED

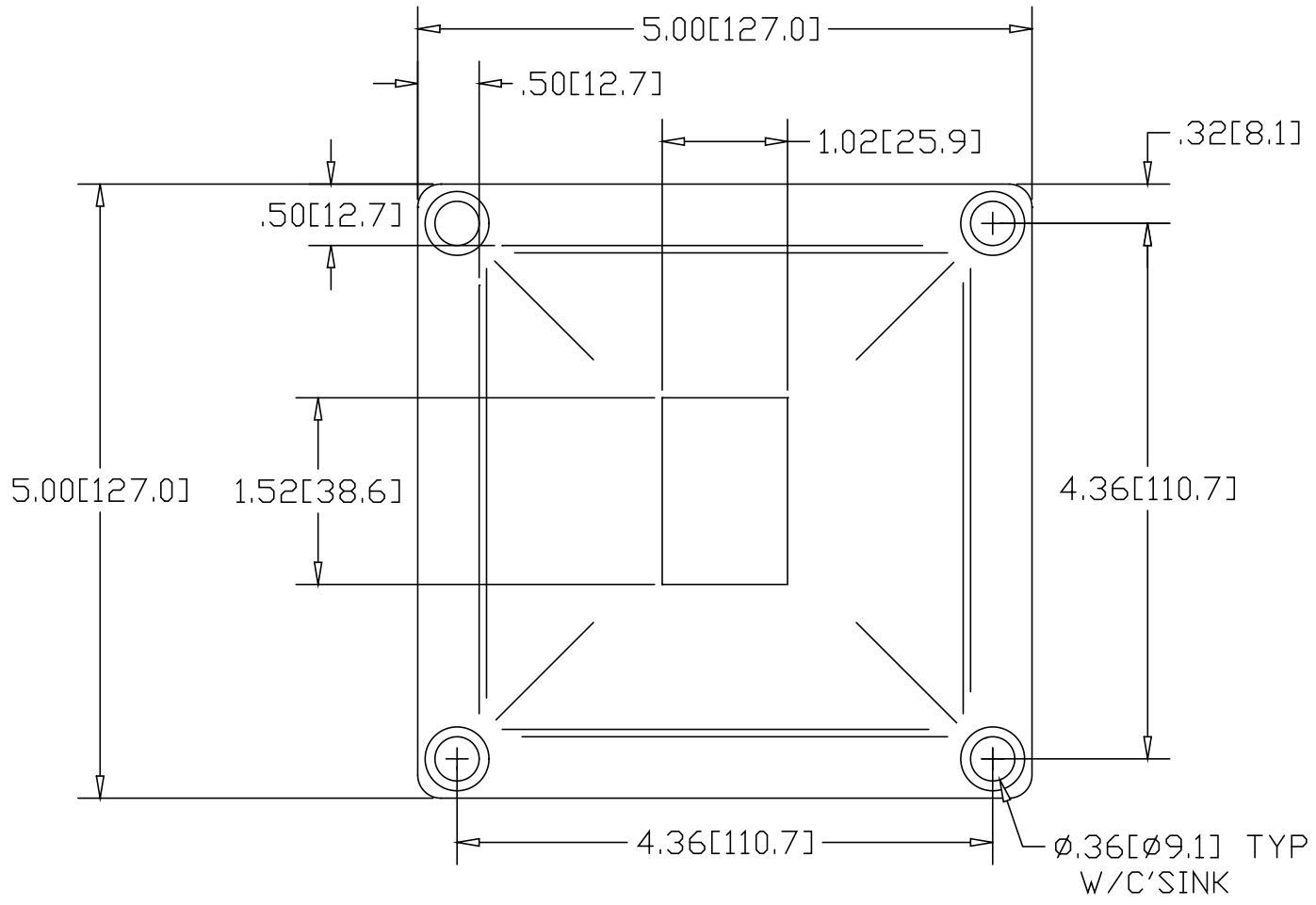

*USE WITH ANCHOR PLATE
#8043 IN STEEL
#8044 IN ALUMINUM

INCHES [MILLIMETERS]

ALTERNATE MATERIAL	PART NUMBER
.190 (3003) ALUMINUM ASTM B209	8054

PART NAME 1" X 1-1/2" RECTANGULAR TUBE FLANGE			
MATERIAL 7 GA. HRP&D STEEL ASTM A569			
DATE 6/12/96		R & B WAGNER, INC.	
DRAWN BY RJF			
FINISH MILL	SIZE A	WEIGHT 1.2 LBS	PART NUMBER 8053
			REV