

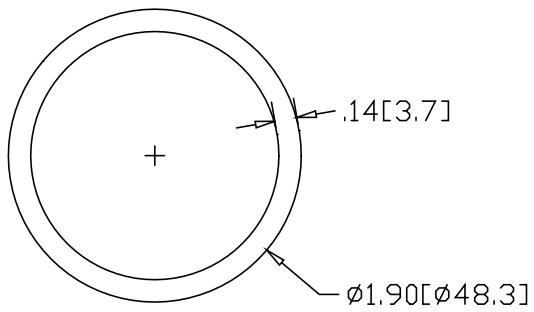

REV
SH
4665
DWG NO

REVISIONS			
REV	DESCRIPTION	DATE	APPROVED

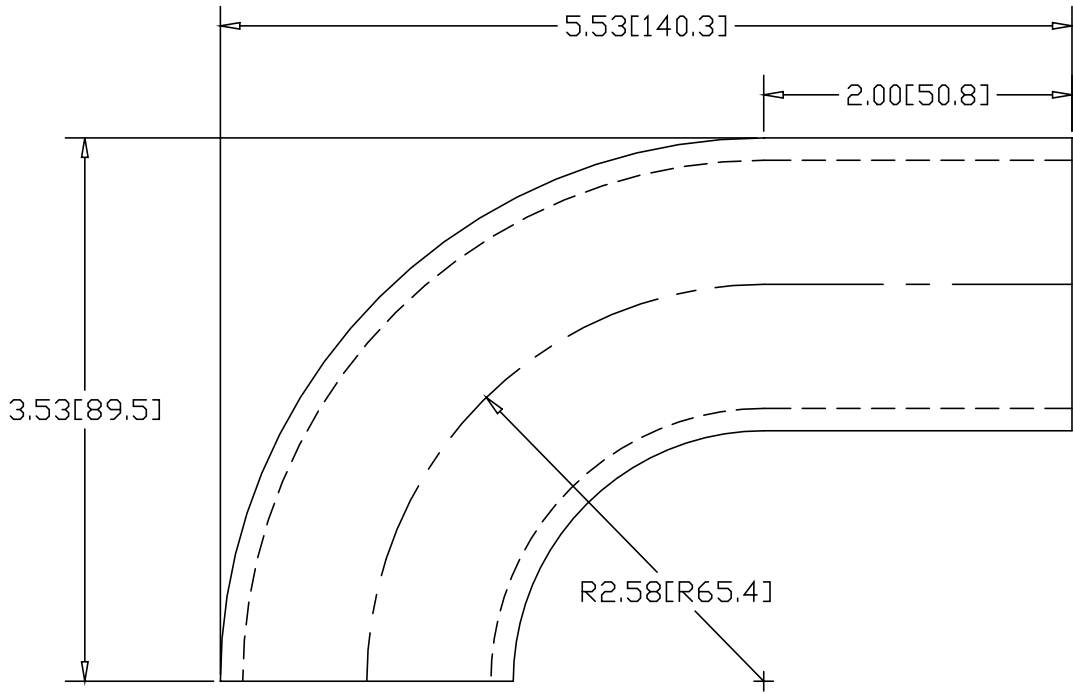

INCHES [MILLIMETERS]

ALTERNATE MATERIAL	PART NUMBER
1-1/2" SCH 40 (6063) ALUMINUM PIPE	4675
1-1/2" SCH 40 (304) STAINLESS STEEL PIPE	4685

PART NAME 1-1/2" PIPE SIZE 90° ELL X 1-5/8" I.R. W/(1) 2" TANGENT			
MATERIAL 1-1/2" SCH 40 STEEL PIPE			
DATE 8/18/95		R & B WAGNER, INC.	
DRAWN BY RJF		SIZE A	WEIGHT 1.26 LBS
FINISH MILL			REV