

REVISIONS			
REV	DESCRIPTION	DATE	APPROVED

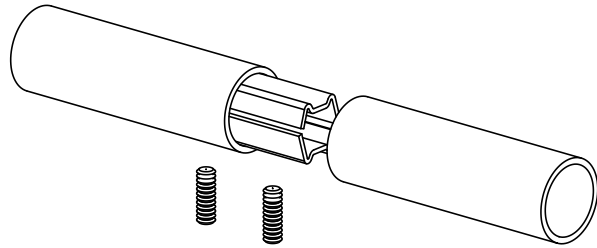

2.00" OD X .065W TUBE

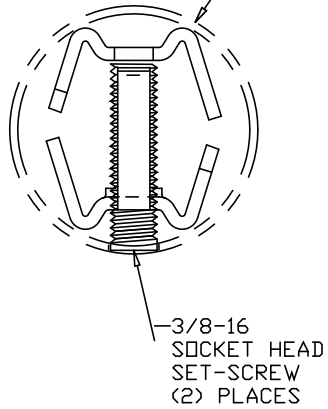

3/8-16 SOCKET HEAD SET-SCREW (2) PLACES

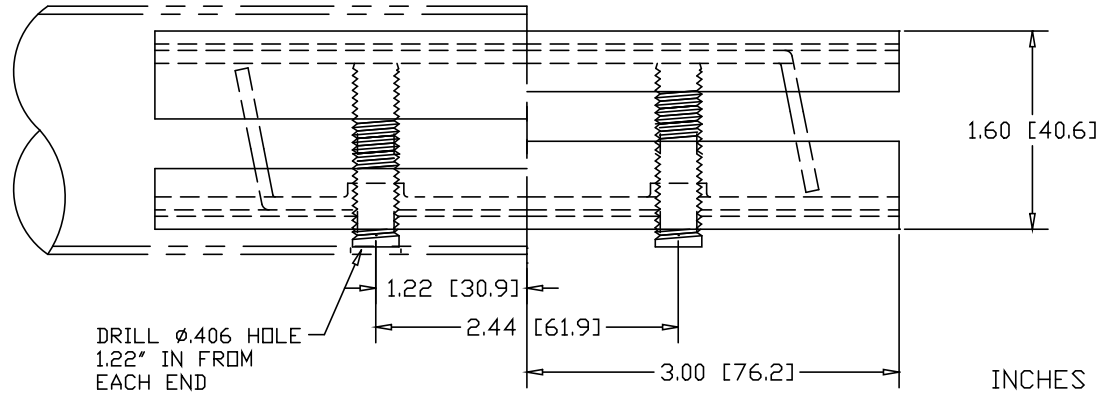
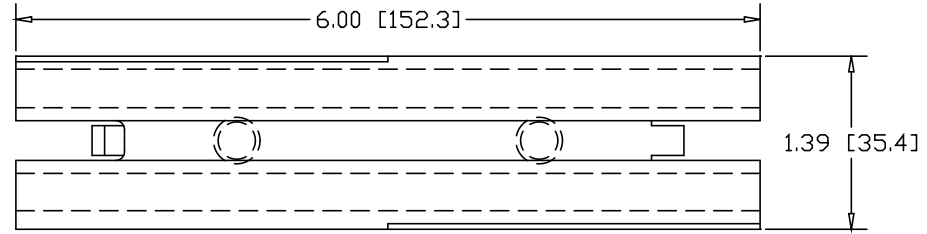

DRILL  $\phi$ .406 HOLE 1.22" IN FROM EACH END

INCHES [MILLIMETERS]

ALTERNATE MATERIAL	PART NO.
12 GA. STEEL HOT DIP GALVANIZED	G3378-6
12 GA. STEEL ZINC PLATED	PL3378-6
.125 (3003) ALUMINUM ASTM B209	3379-6
.090 (304) STAINLESS STEEL ASTM A240	3380-6

PART NAME		2.00" OD X .065W DOUBLE-LOCK SPLICE-LOCK 6" LONG			
MATERIAL		12 GA. HRP&D STEEL ASTM A569			
DATE	3/22/93	 <b>THE WAGNER COMPANIES</b> R & B WAGNER, INC. AND J. G. BRAUN CO.			
DRAWN BY	RJF				
FINISH	MILL				
SIZE	A	WEIGHT	.88 LBS	PART NUMBER	3378-6
				REV	