

REVISIONS			
REV	DESCRIPTION	DATE	APPROVED

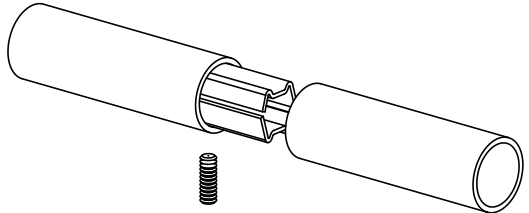

2" SCHEDULE 80 PIPE  
(2.38 DIA X .218W)

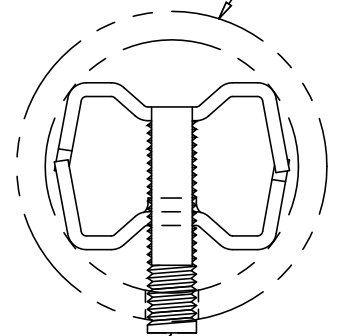
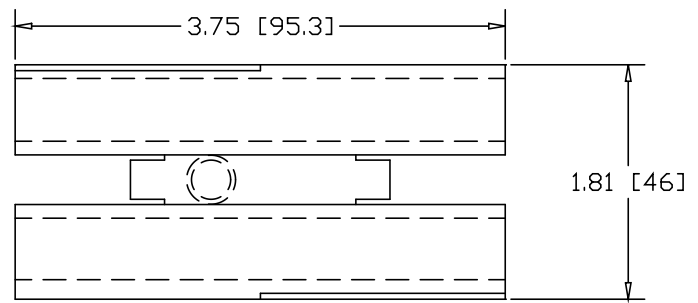

3/8-16 SOCKET HEAD  
SET-SCREW X 1-5/8" LONG

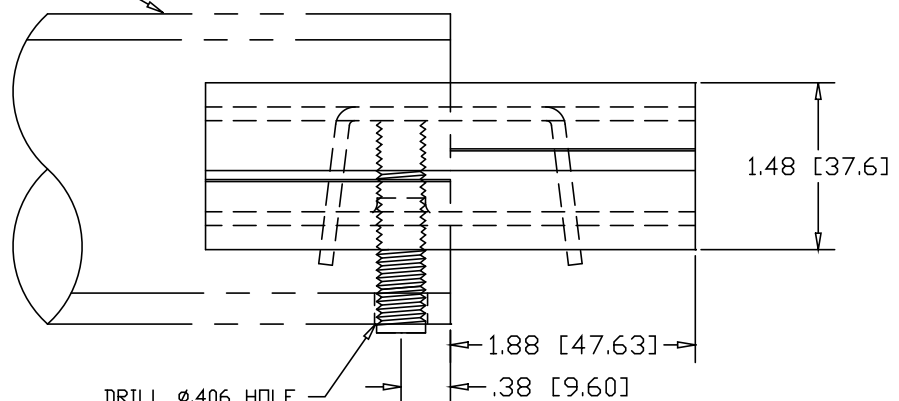

DRILL  $\phi$ .406 HOLE  
.38" IN FROM END

INCHES [MILLIMETERS]

ALTERNATE MATERIAL	PART NO.
12 GA. STEEL HOT DIP GALVANIZED	G3330
12 GA. STEEL ZINC PLATED	PL3330
.125 (3003) ALUMINUM ASTM B209	3323H

PART NAME		2" SCH80 PIPE SINGLE-LOCK SPLICE-LOCK		
MATERIAL		12 GA. HRP&D STEEL ASTM A569		
DATE	9/19/01		<b>THE WAGNER COMPANIES</b> R & B WAGNER, INC. AND J. G. BRAUN CO.	
DRAWN BY	JAH			
FINISH	MILL	SIZE	WEIGHT	PART NUMBER
		A	.52 LBS	3330
				REV