

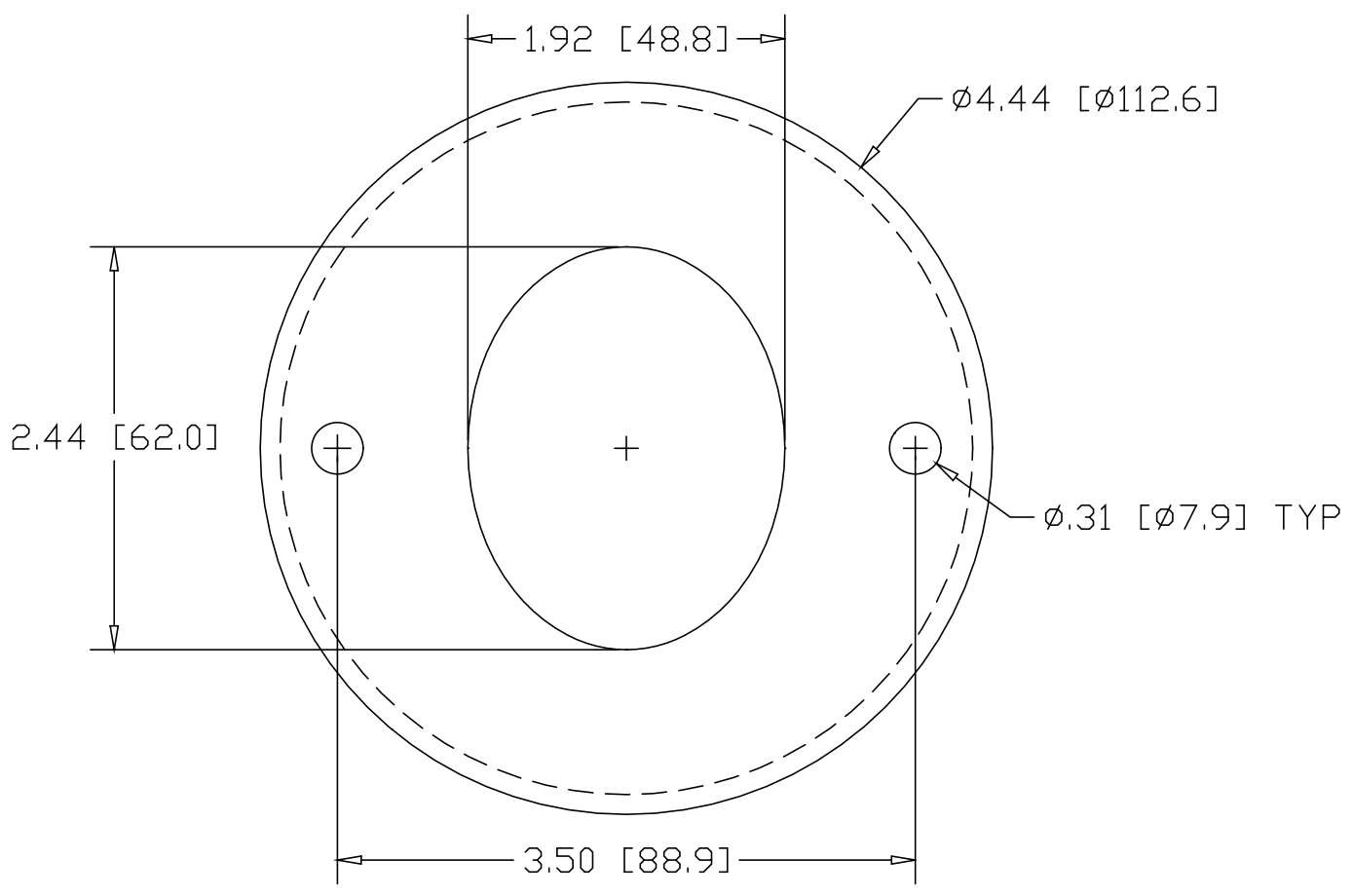

REV
SH
2835
DWG NO

REVISIONS			
REV	DESCRIPTION	DATE	APPROVED



INCHES [MILLIMETERS]

ALTERNATE MATERIAL	PART NUMBER
.125 (3003) ALUMINUM ASTM B209	2875
10 GA. (304) STAINLESS STEEL ASTM A240	2915

PART NAME 1-1/2" PIPE HEAVY FLUSH BASE BEVELED FLANGE W/(2) HOLES				
MATERIAL 10 GA. HRP&D STEEL ASTM A569				
DATE 9/6/94	 THE WAGNER COMPANIES R & B WAGNER, INC. AND J. G. BRAUN CO.			
DRAWN BY RJF		SIZE A	WEIGHT .63 LBS	PART NUMBER 2835
FINISH MILL				REV