

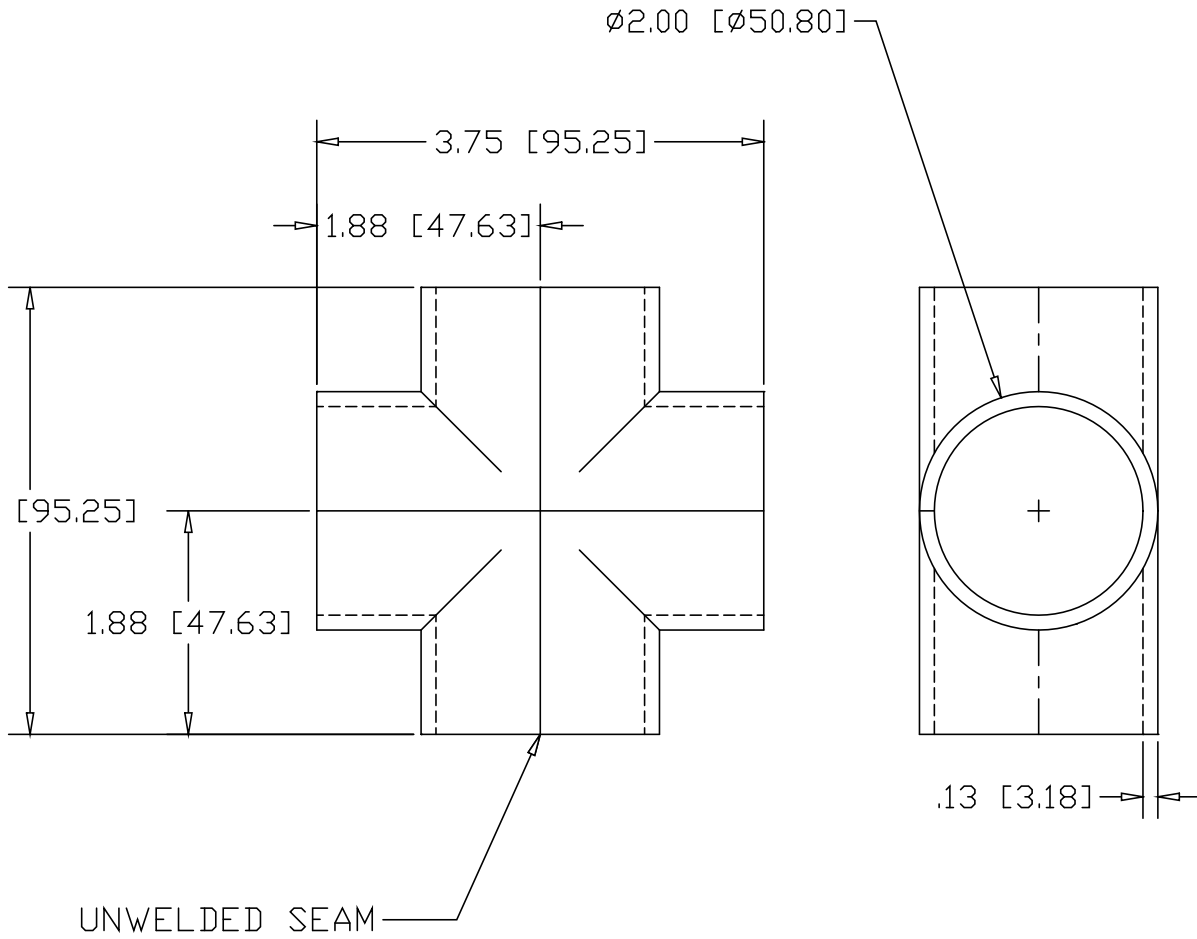

REV
SH
2108
DWG NO

REVISIONS			
REV	DESCRIPTION	DATE	APPROVED



INCHES [MILLIMETERS]

PART NAME		2" OD TUBE SIZE STEEL CROSS			
MATERIAL		10 GA. HRP&D STEEL ASTM A569			
DATE	1/08/02	 R & B WAGNER, INC.			
DRAWN BY	JAH				
FINISH	MILL	SIZE	WEIGHT	PART NUMBER	REV
		A	1.07 LBS	2108	