

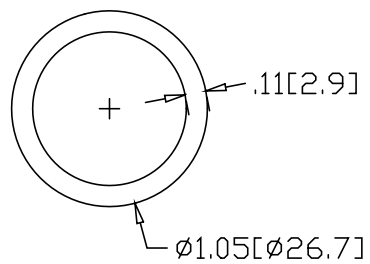

REV
SH
157-8
DWG NO

REVISIONS			
REV	DESCRIPTION	DATE	APPROVED

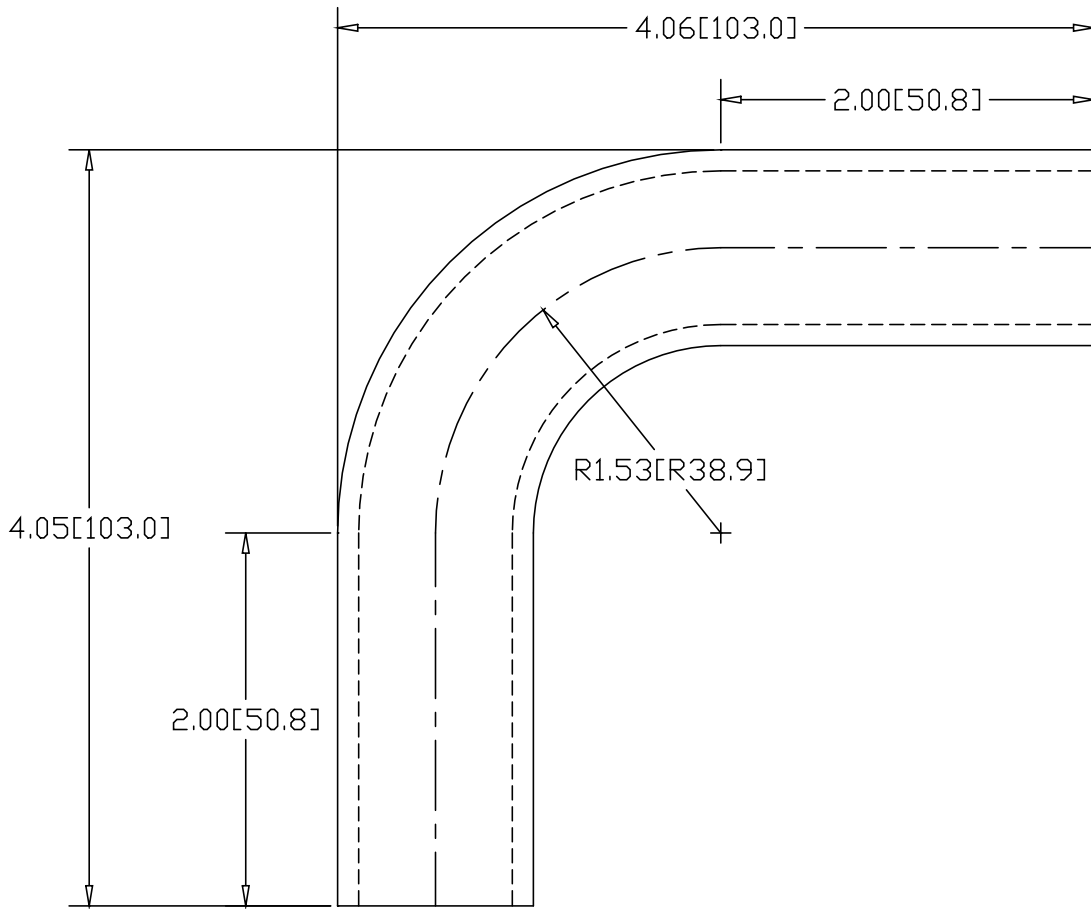

INCHES [MILLIMETERS]

ALTERNATE MATERIAL	PART NUMBER
3/4" SCH 40 (6063) ALUMINUM PIPE	166

PART NAME		3/4" PIPE 1" I.R. X 90° ELL W/(2) 2" TANGENTS		
MATERIAL		3/4" SCH 40 A53 STEEL PIPE		
DATE	8/17/95	 R & B WAGNER, INC.		
DRAWN BY	RJF			
FINISH	MILL	SIZE	WEIGHT	PART NUMBER
		A	.60 LBS	157-8
				REV