

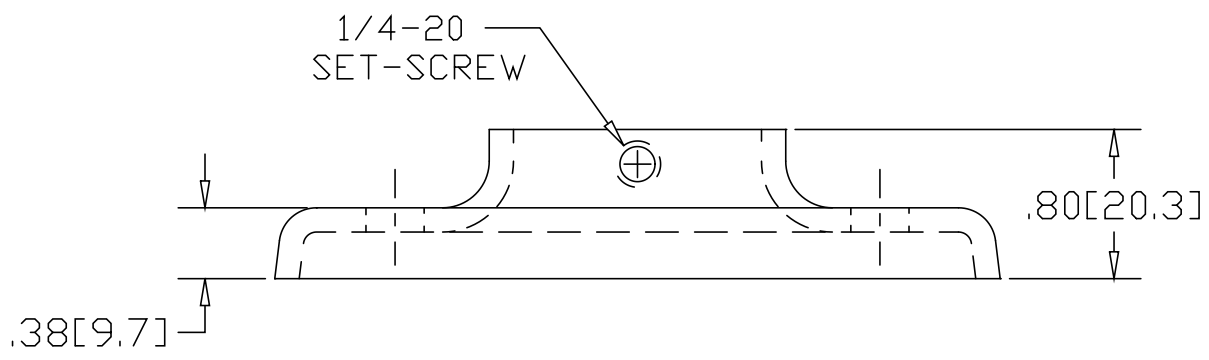

REV
SH
1422A
DWG NO

REVISIONS			
REV	DESCRIPTION	DATE	APPROVED

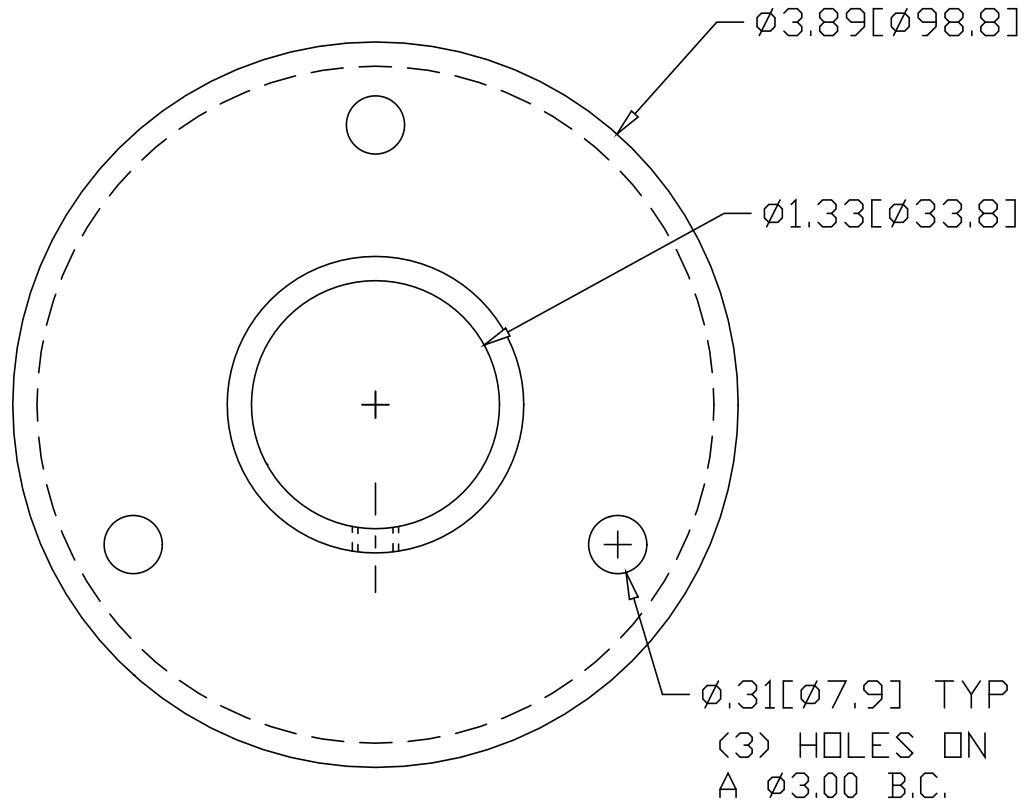

INCHES [MILLIMETERS]

ALTERNATE MATERIAL	PART NUMBER
.125 (3003) ALUMINUM ASTM B209	1462A
10 GA. (304) STAINLESS STEEL ASTM A240	1522A

PART NAME 1" PIPE HEAVY BASE FLANGE W/(3) HOLES AND SET-SCREW			
MATERIAL 10 GA. HRP&D STEEL ASTM A569			
DATE 9/13/94		R & B WAGNER, INC.	
DRAWN BY RJF		SIZE A	WEIGHT .50 LBS
FINISH MILL		PART NUMBER 1422A	REV